



Mobile Filter Unit MFU-15

Description

The MFU 15 Mobile Filtration unit is used as a portable service unit for filling hydraulic systems, flushing small hydraulic systems as well as for cleaning in bypass flow. Solid particle contamination as well as free water can be removed by the filter elements.

The MFU 15 can also be fitted with a CS 1000 Contamination Sensor. This allows the solid particle contamination in the oil to be monitored at the same time. The cleanliness class results are displayed according to ISO, SAE or NAS classifications.

Applications

- Filtered and unfiltered filling of hydraulic systems
- Temporary offline filtration of hydraulic systems
- Filtered or unfiltered fluid transfer
- Unfiltered drainage of hydraulic tanks
- Leakage oil recirculation at test benches

Special features

- Improvement in service life for components and system filters
- Increased oil service life
- Increased machine availability
- Simple operation
- Compact design
- Integrated dry running protection
- Option: CS 1000 ensures continuous monitoring of oil cleanliness during cleaning

Technical details

General data

Maximum flow rate	MFU-E / MFU-S: 15 l/min MFU-P: 10 l/min
Pump type	Vane pump
Maximum operating pressure	4.0 bar
Permitted suction pressure at suction port	-0.4 bar to + 0.6 bar
Viscosity range	MFU-E: 5 ... 350 mm ² /s MFU-S: 5 ... 650 mm ² /s MFU-P: 5 ... 200 mm ² /s
Length of power cable	3 m (incl. plug)
Length of signal cable (for standard type)	10 m
Permissible fluid temperature	-10 ... +80 °C
Permitted ambient temperature range	-10 to +40°C
Seal material	FKM (FPM, Viton®)
Empty weight	MFU-E: 14 kg MFU-S: 17 kg MFU-P: 16.5 kg

Preferred models (with shorter delivery times)

Filtration unit	Part no.
MFU-15E9-SM-FE	4263416
MFU-15S9-SN-FE	4269896
MFU-10P9-SM-FE	4263417



Order details

	MFU - 15 E 9 - S M - F E / -
Basic Type	_____
MFU = Mobile Filter Unit	
Size	_____
15 = 15 l/min (for type "E" and "S")	
10 = 10 l/min (for type "P")	
Type	_____
E = Economy	
S = Standard (with signal cable for "Device in operation")	
P = Premium (with Condition Monitoring)	
Element length	_____
9 = 9"	
Pump version	_____
S = Vane pump	
Power supply	_____
D = Compressed air (only available for type E)	
K = 120 V, 60 Hz, 1 Ph (0.25 kW)	
M = 230 V, 50 Hz, 1 Ph (0.25 kW)	
N = 400 V, 50 Hz, 3 Ph (0.37 kW) (only available for type S)	
T = 12 V DC (0.2 kW) (only available for type E and P)	
U = 24 V DC (0.2 kW) (only available for type E and P)	
others on request	
Material of seal	_____
F = FKM (FPM, Viton®)	
others on request	
Clogging indicator	_____
E = Back-pressure indicator	
Supplementary details	_____

Scope of delivery

- MFU (without filter element;
without hoses)
- Operating and maintenance instructions

Filter elements and hoses must be ordered separately and installed before operation on site. For this purpose, please observe the next page.

Filter elements

Description	Part no.	Filtration rating	Water absorption
Filtration			
NX9DM002-F	4265955	2 µm	-
NX9DM005-F	4265956	5 µm	-
NX9DM010-F	4265957	10 µm	-
NX9DM020-F	4265958	20 µm	-
Filtration and dewatering			
NX9AM002-F	4265959	2 µm	✓
NX9AM005-F	4265960	5 µm	✓
NX9AM010-F	4265961	10 µm	✓
NX9AM020-F	4265962	20 µm	✓
Adapter for unfiltered operation			
NX9-xxxxx-F	4265963	-	-



Accessories

Hoses with lance (depressurized suction up to max. 350 mm²/s)

Description	Part no.	Suction hose / Pressure hose	Lance	Material Suction / pressure hose
MFU-15-SDN	4270478	2.5 m / 2.5 m	0.25 m	PVC / PVC
MFU-15-SDF	4270479	2.5 m / 2.5 m	0.25 m	1SN / 2TE
MFU-15-SD5N	4270480	2.5 m / 5 m	0.25 m	PVC / PVC
MFU-15-SD5F	4270481	2.5 m / 5 m	0.25 m	1SN / 2TE

Hoses with threaded connection (depressurized suction up to max. 350 mm²/s)

Description	Part no.	Suction hose / Pressure hose	Thread	Material Suction / pressure hose
MFU-15-SKDKN	4270482	2.5 m / 2.5 m	M30x2 / M26x1.5	PVC / PVC
MFU-15-SKDKF	4270483	2.5 m / 2.5 m	M30x2 / M26x1.5	1SN / 2TE
MFU-15-SKDK5N	4270484	2.5 m / 5 m	M30x2 / M26x1.5	PVC / PVC
MFU-15-SKDK5F	4270516	2.5 m / 5 m	M30x2 / M26x1.5	1SN / 2TE

Accessories for hoses with threaded connection

Description	Part no.	Function
MFU-15-SKDK-LF	4270559	Lance ¹ (length of 1.30 m)
MFU-15-SKDK-SF	4270560	Suction filter ¹
MFU-15-SKDK-ZWF	4270518	Counter
MFU-15-SKDK-ZPF	4270561	Pump nozzle ²
MFU-15-SKDK-ZPWF	4270519	Pump nozzle + counter ²

¹ max. viscosity 200 mm²/s

² max. operation duration of the unit with closed pump nozzle of 5 - 10 min.

Dimensions – MFU-15E

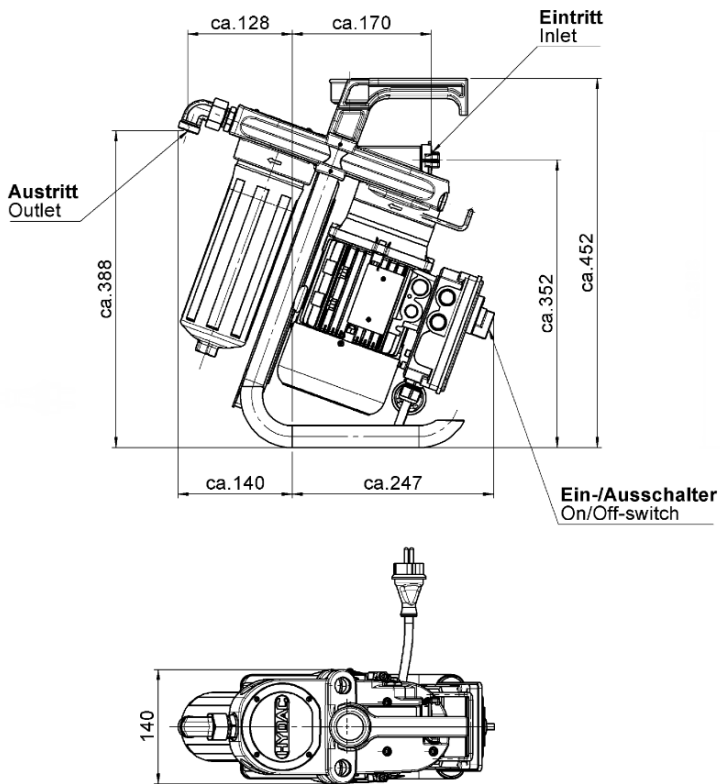

(All dimensions in mm)

Dimensions – MFU-15S

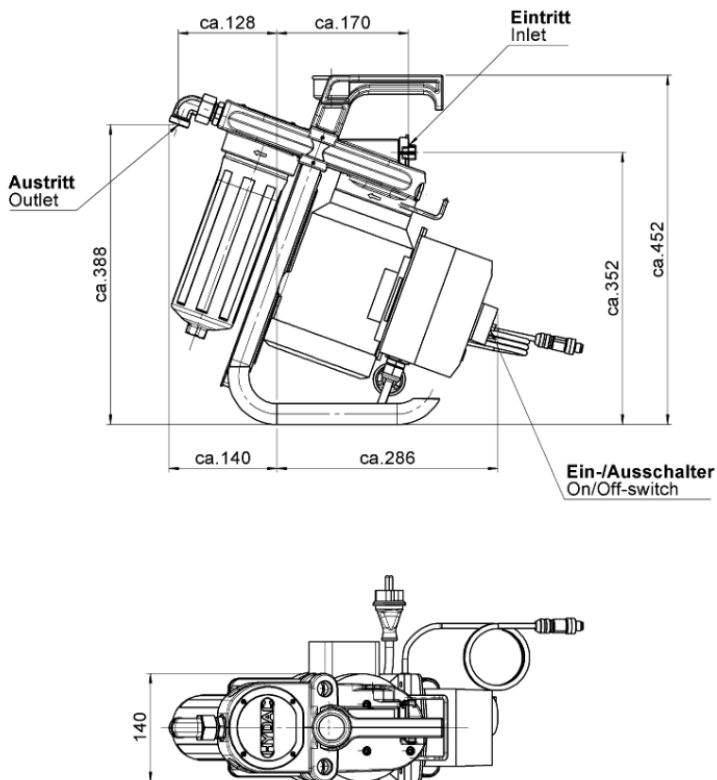

(All dimensions in mm)

Hydraulic circuit:

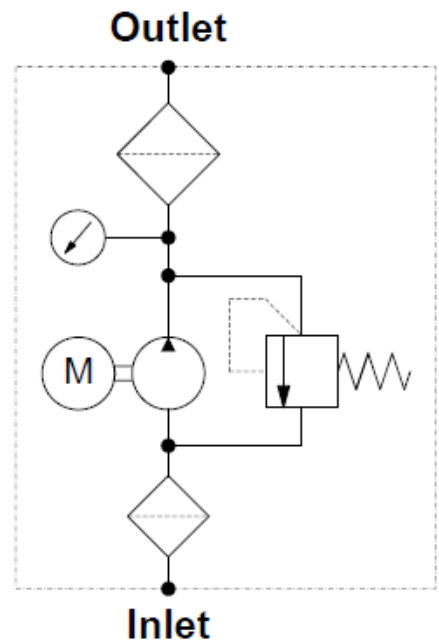

Dimensions – MFU-15P

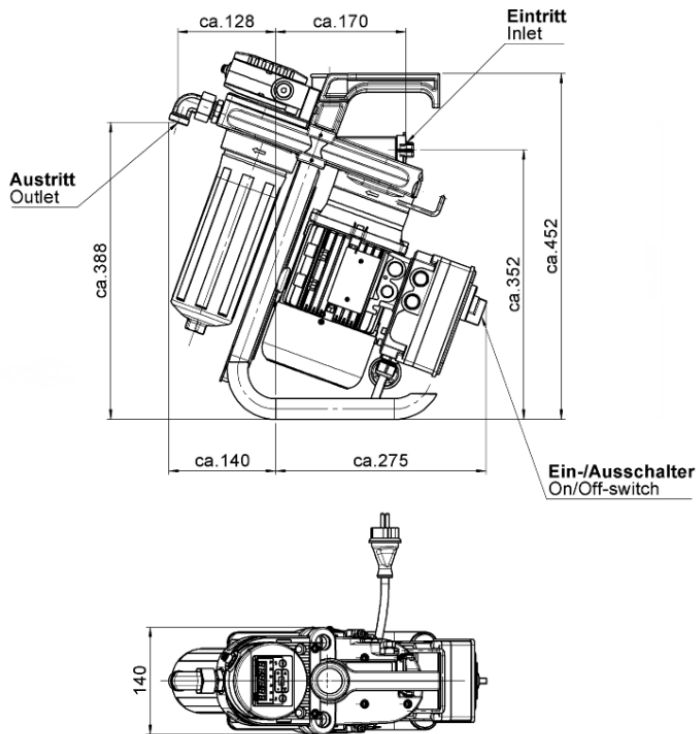

(All dimensions in mm)

Hydraulic circuit:

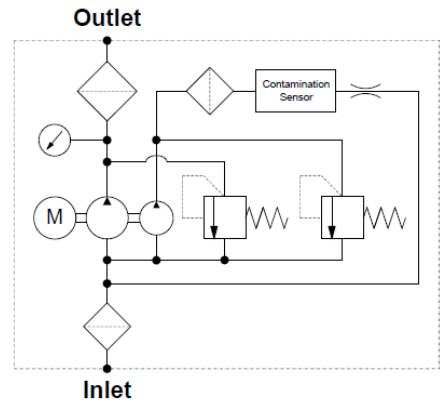

Note:

The information in this brochure relates to the operating conditions and applications described.

In the event of deviating applications and/or operating conditions, please contact the respective department concerned.

Subject to technical modifications.

HYDAC FILTER SYSTEMS GMBH

Industriestrasse
D-66280 Sulzbach / Saar

Telephone: +49 (0)6897 / 509-01

Fax: +49 (0)6897 / 509-9046

Internet: www.hydac.com
E-mail: filtersystems@hydac.com