

Change-Over Filter NFD

up to 1600 l/min, up to 25 bar

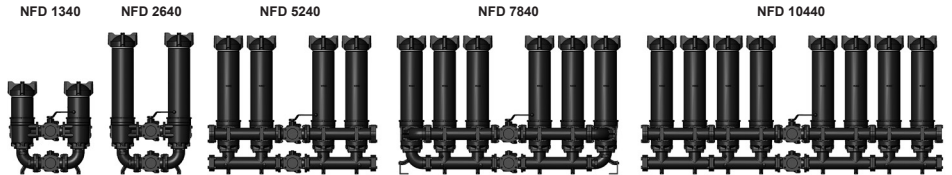

1. TECHNICAL SPECIFICATIONS

1.1 FILTER HOUSING Construction

The filter housings are designed in accordance with international regulations. They consist of a filter housing and a threaded cover plate. The housings are connected by a ball change-over valve.

Standard equipment:

- connection for a clogging indicator in filter head
- with bypass valve

1.2 FILTER ELEMENTS

HYDAC filter elements are validated and their quality is constantly monitored according to the following standards:

- ISO 2941
- ISO 2942
- ISO 2943
- ISO 3724
- ISO 3968
- ISO 11170
- ISO 16889

Number of filter elements

NFD	Elements per side
1340	1x1300 R
2640	1x2600 R
5240	2x2600 R
7840	3x2600 R
10440	4x2600 R

Filter elements are available with the following pressure stability values:

Optimicon® (ON):	20 bar
Optimicon® Pulp & Paper (ON/PP):	10 bar
Ecomicon® (ECON2):	10 bar
Stainl. st. wire mesh (W/HC):	20 bar
Stainless steel fibre (V):	210 bar
Paper (P/HC):	10 bar
Betamicron®/Aquamicron® (BN4AM):	10 bar
Aquamicron® (AM):	10 bar

1.3 FILTER SPECIFICATIONS

Nominal pressure	25 bar
Max. operating pressure	30 bar at max. 10 ⁶ cycles
Temperature range	-10 °C to +100 °C
Material of filter head, tube and cover plate	Aluminium
Material of change-over valve, elbow and connection piece	EN-GJS-400-15
Type of clogging indicator	VM (differential pressure measurement)
Pressure setting of the clogging indicator	2 bar (others on request)
Bypass cracking pressure	3 bar (others on request)

1.4 SEALS

NBR (=Perbunan)

1.5 INSTALLATION

Inline filter

1.6 SPECIAL MODELS AND ACCESSORIES

- Seals in FPM
- NFD filter as tank-top return line filter (type code 1.x) on request

1.7 SPARE PARTS

See Original Spare Parts List

1.8 CERTIFICATES AND APPROVALS

On request

1.9 COMPATIBILITY WITH HYDRAULIC FLUIDS ISO 2943

- Hydraulic oils H to HLPD DIN 51524
- Lubrication oils DIN 51517, API, ACEA, DIN 51515, ISO 6743
- Compressor oils DIN 51506
- Biodegradable operating fluids VDMA 24568 HETG, HEES, HEPG
- Fire-resistant fluids HFA, HFB, HFC and HFD
- Operating fluids with high water content (>50% water content) on request

1.10 IMPORTANT INFORMATION

- Filter housings must be earthed.
- When using visual clogging indicators, the BM version (visual with manual reset) only should be used.
- When using electrical clogging indicators, the electrical power supply to the system must be switched off before removing the clogging indicator connector.

Symbol for hydraulic systems

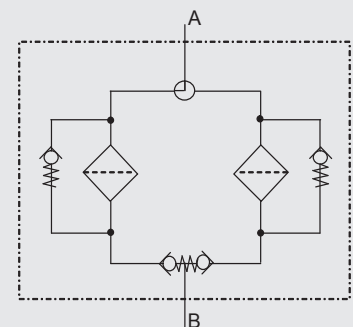

2. MODEL CODE (also order example)

NFD ON 2640 D A P 10 D 2 . X /-L24

2.1. COMPLETE FILTER

Filter type

NFD

Filtermaterial

ON Optimicron® P/HC Paper
 ON/PP Optimicron® Pulp & Paper W/HC Stainl. st. wire mesh
 V Stainless steel fibre ECO/N ECOMircron® (ECON2)
 BN/AM Betamicron®/Aquamicron® AM Aquamicron®

Size of filter or element

NFD: 1340, 2640, 5240, 7840, 10440

Operating pressure

D = 25 bar

Type of change-over

A = Ball

Type and size of port

Type	Port	Filter size				
		1340	2640	5240	7840	10440
P	SAE DN 100	●	●	●	●	●

Other types and sizes of port on request!
 For examples, see point 3.3

Filtration rating in µm

ON: 1, 3, 5, 10, 15, 20 ECO/N, V: 3, 5, 10, 20 P/HC: 10, 20 AM: 40
 ON/PP: 5 W/HC: 25, 50, 100, 200 BN/AM: 3, 10

Type of clogging indicator

Y plastic blanking plug in indicator port
 A steel blanking plug in indicator port
 B visual
 C electrical
 D visual and electrical
 for other clogging indicators see brochure no. 7.050../..

Type code (TKZ)

2

Modification number

X the latest version is always supplied

Supplementary details

B. special cracking pressure of bypass (e. g.: B6 = 6 bar)
 EM manual vent with shut-off valve
 EP permanent vent via Minimess hose
 KB without bypass valve
 L... light with appropriate voltage (24, 48, 110, 220 Volt)
 LED 2 light emitting diodes up to 24 Volt
 SB4 filling line with Ø4 mm orifice
 V FPM seals
 VKD drain fitted with ball shut-off valve
 39 connection alternative (see point 2.4)
 only for clogging indicators type "D"

2.2 REPLACEMENT ELEMENT

2600 R 010 ON /-V

Size

1300, 2600

Type

Filtration rating in µm

ON: 001, 003, 005, 010, 015, 020 ECON2, V: 003, 005, 010, 020 P/HC: 010, 020 AM: 040
 ON/PP: 005 W/HC: 025, 050, 100, 200 BN4AM: 003, 010

Filter material

ON, ON/PP, ECON2, V, W/HC, P/HC, BN4AM, AM

Supplementary details

V (for descriptions, see point 2.1)

2.3 REPLACEMENT CLOGGING INDICATOR

VM 2 D . X /-L24

Type

VM differential pressure measurement up to 210 bar operating pressure

Pressure setting

2 standard 2 bar, others on request

Type of clogging indicator (see point 2.1)

Modification number

X the latest version is always supplied

Supplementary details

L..., LED, V (for descriptions, see point 2.1)

2.4 CONNECTION ALTERNATIVES

(also order example)

Supplementary detail .. / - 0 3

1st digit = position of inlet valve

2nd digit = position of outlet valve

33
Standard

Standard model:
Not given as a supplementary detail in the model code

~~63~~

Not available!

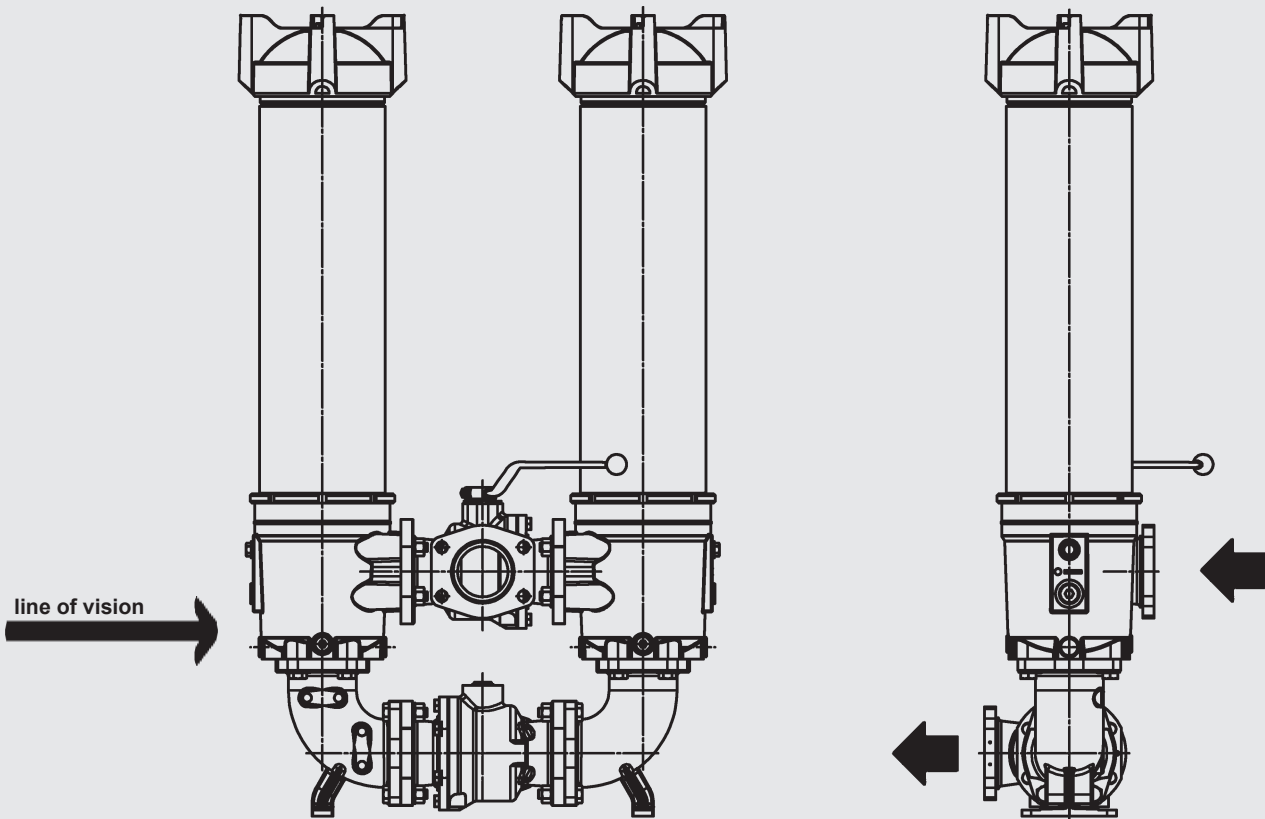
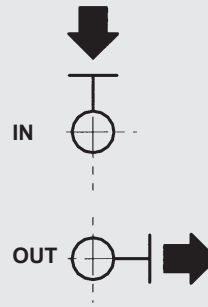

Line of vision
Type code .. / -39

NFD 2640 .. A 2.0 / -XX
(possible supplementary detail)

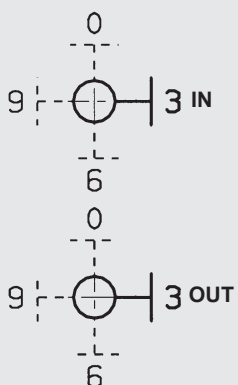

00	03	06	09 ¹⁾
30	33 Standard	36	39
60	63	66	69
90	93	96	99 ³⁾

- 1) corresponds to type 03
- 2) corresponds to type 39
- 3) corresponds to type 33

NFD 5240 .. A 2.0 / -XX
(possible supplementary detail)

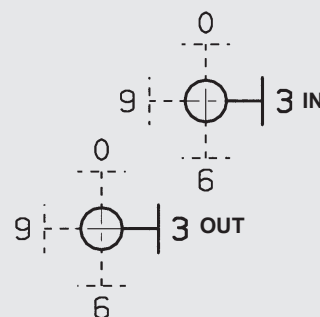

00	03	06	09
30	33 Standard	36	39
60	63	66	69
90	93	96	99

3. FILTER CALCULATION / SIZING

The total pressure drop of a filter at a certain flow rate Q is the sum of the housing Δp and the element Δp and is calculated as follows:

$$\Delta p_{\text{total}} = \Delta p_{\text{housing}} + \Delta p_{\text{element}}$$

$\Delta p_{\text{housing}}$ = given in diagrams (see point 3.1)

$$\Delta p_{\text{element}} = Q \cdot \frac{SK^*}{1000} \cdot \frac{\text{viscosity}}{30}$$

(*see Point 3.2)

For ease of calculation, our Filter Sizing Program is available on request free of charge.

NEW: Sizing online at www.hydac.com

3.1 Δp -Q HOUSING CURVES BASED ON ISO 3968

The housing curves apply to mineral oil with a density of 0.86 kg/dm³ and a kinematic viscosity of 30 mm²/s. In this case, the differential pressure changes proportionally to the density.

NFD 1340 / 2640

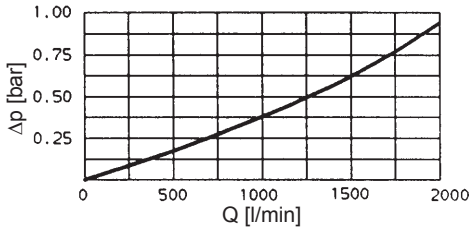

NFD 5240

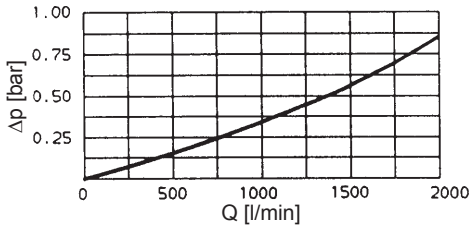

NFD 7840

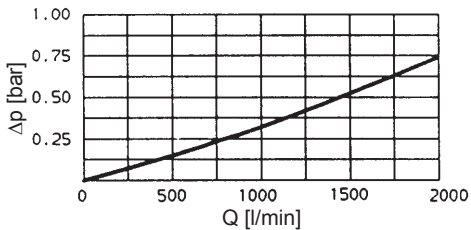

NFD 10440

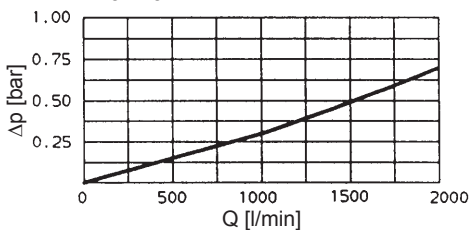

3.2 GRADIENT COEFFICIENTS (SK) FOR FILTER ELEMENTS

The gradient coefficients in mbar/(l/min) apply to mineral oils with a kinematic viscosity of 30 mm²/s. The pressure drop changes proportionally to the change in viscosity.

NFD	ON						ON/PP
	1 μm	3 μm	5 μm	10 μm	15 μm	20 μm	5 μm
1300	1.72	0.72	0.59	0.35	0.32	0.22	1.00
2600	0.84	0.36	0.29	0.18	0.16	0.11	0.45

NFD	V	W/HC				ECON2			
	3 μm	5 μm	10 μm	20 μm	-	3 μm	5 μm	10 μm	20 μm
1300	0.5	0.4	0.3	0.2	0.034	0.8	0.6	0.4	0.3
2600	0.3	0.2	0.1	0.1	0.017	0.4	0.3	0.2	0.1

3.3 OTHER CONNECTION SIZES AND TYPES ON REQUEST!

Examples:

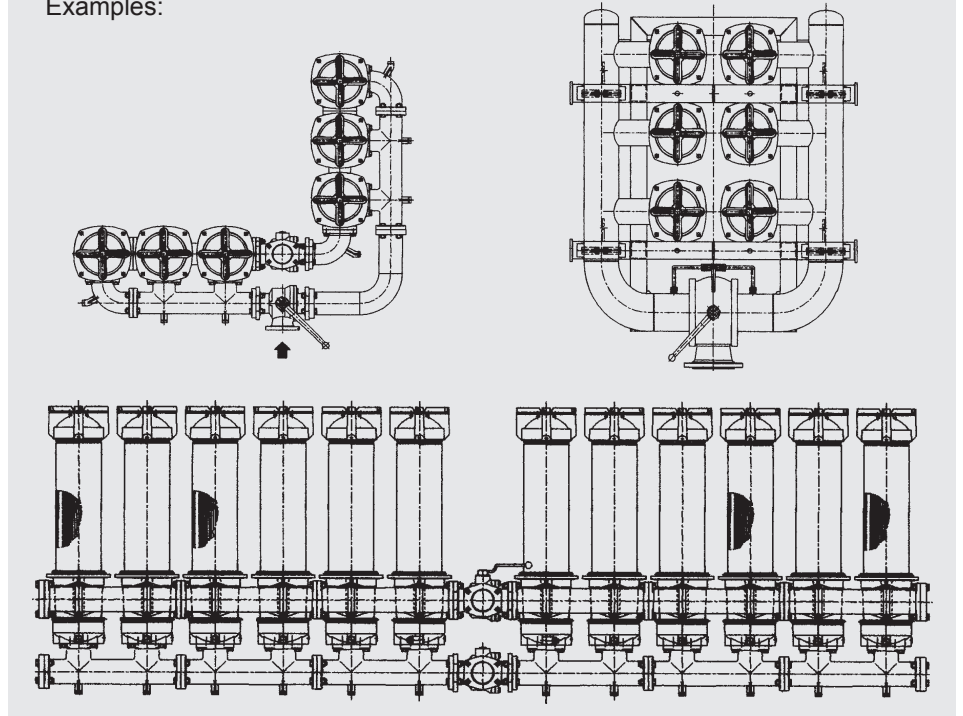

4. DIMENSIONS

NFD 1340/2640

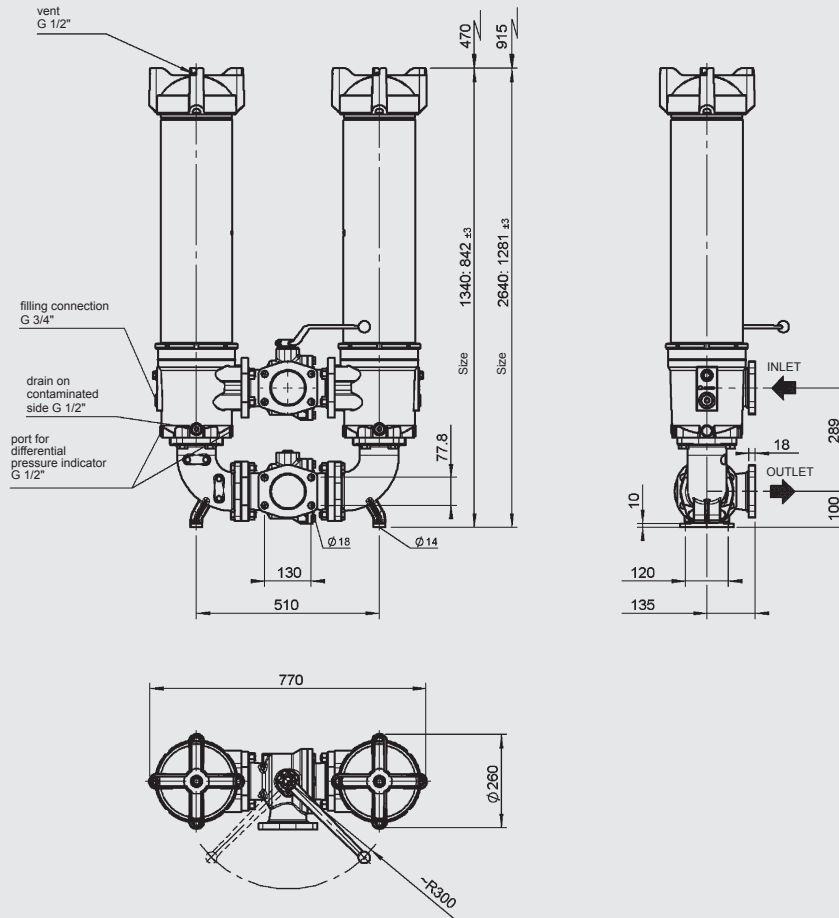

NFD	No. of elements per side	Weight incl. element [kg]	Vol. of pressure chamber [l]
1340...2.X	1x 1300 R...	122.7	35.8
2640...2.X	1x 2600 R...	140.0	58.1

NFD 5240

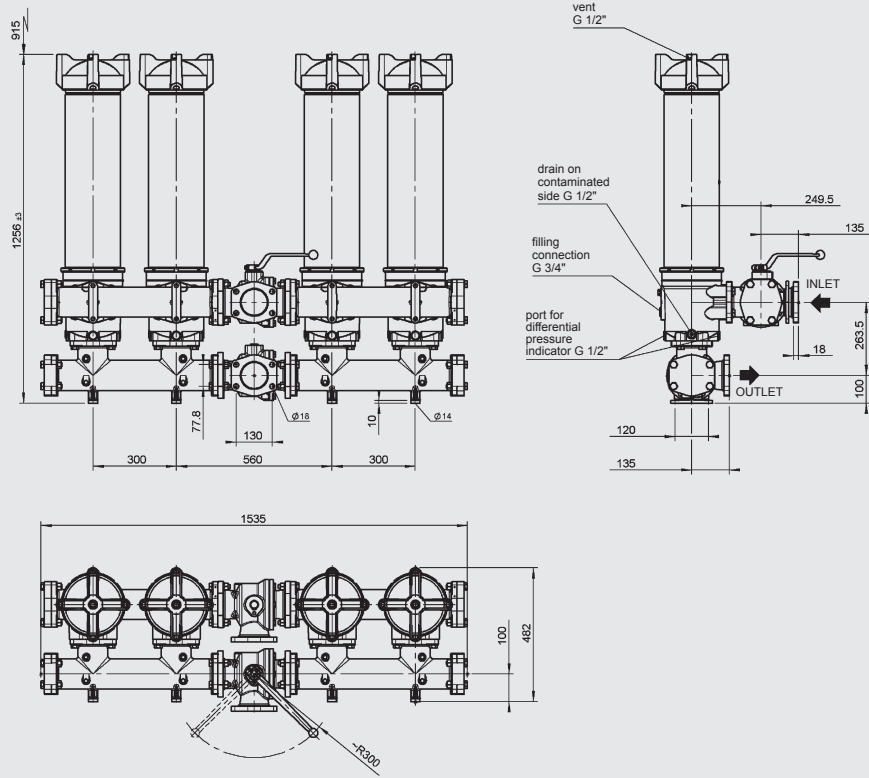

NFD 5240...2.X /-1+2

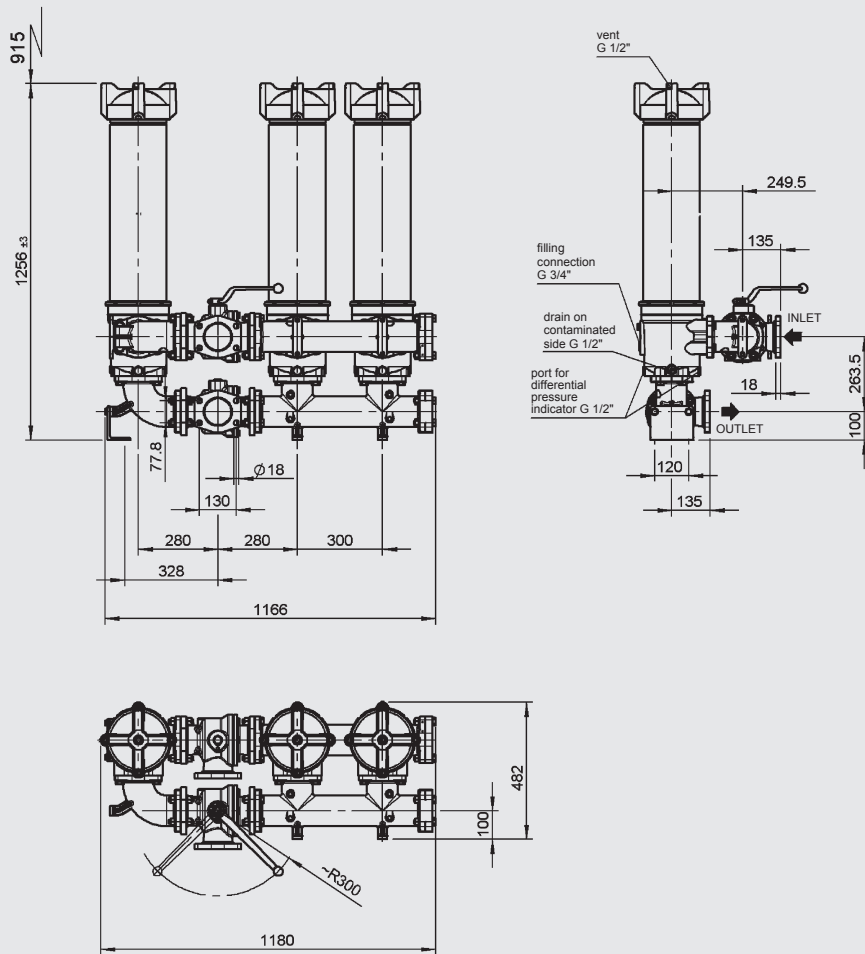

NFD	No. of elements per side	Weight incl. element [kg]	Vol. of pressure chamber [l]
5240...2.X	2x 2600 R...	276.8	126.4
5240../-1+2...2.X	1x 2600 R... and 2x 2600 R...	217.4	94.3

NFD 7840

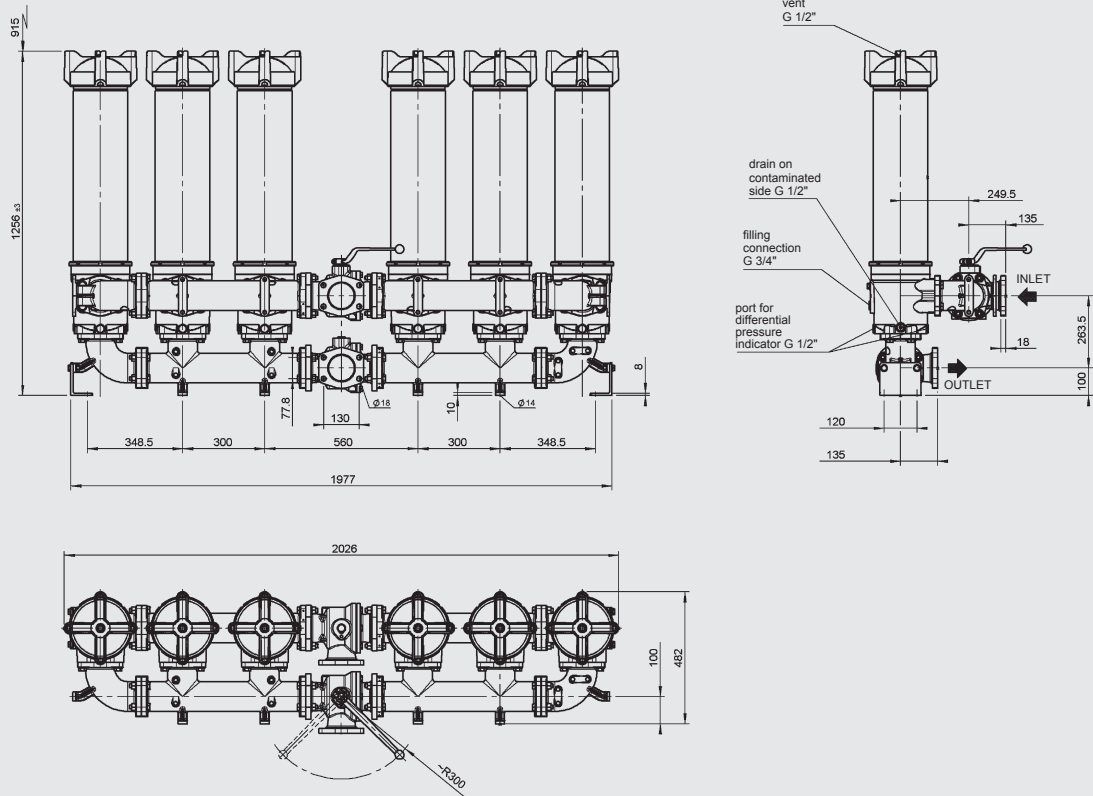

NFD 7840...2.X /-3+1

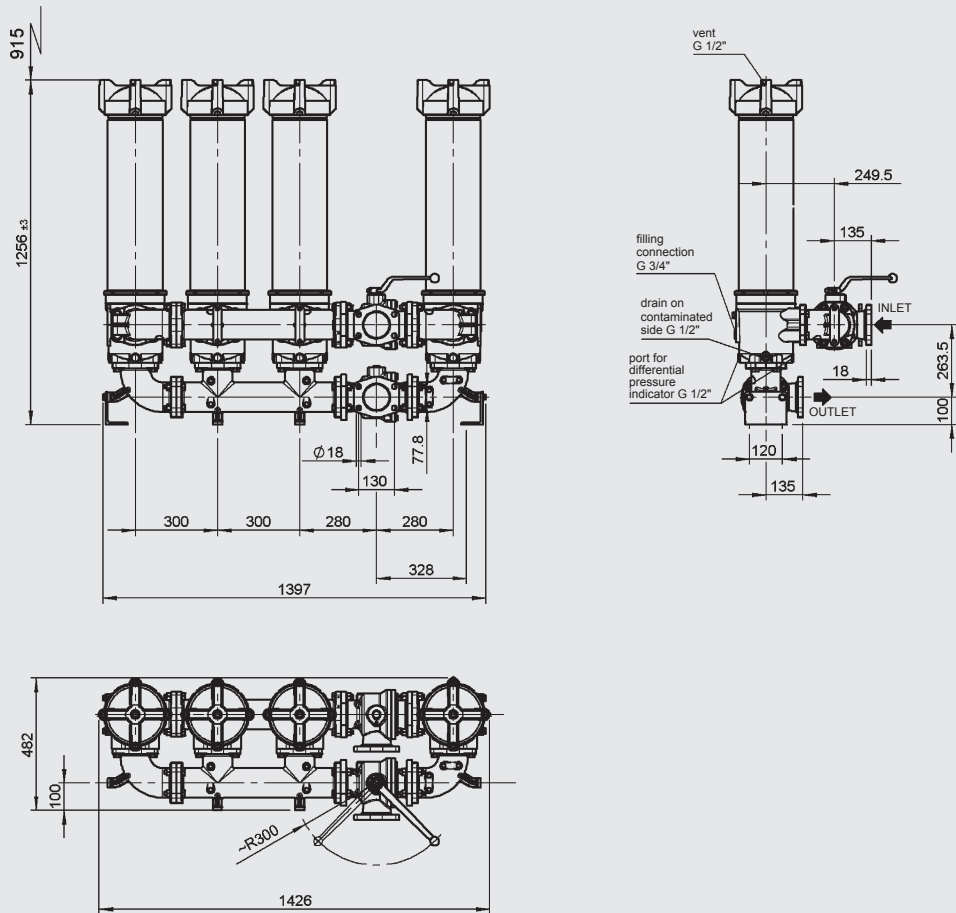

NFD	No. of elements per side	Weight incl. element [kg]	Vol. of pressure chamber [l]
7840	3x 2600 R...	391.6	182.8
7840../-3+1	3x 2600 R... and 1x 2600 R...	286.6	122.2

NFD 10440

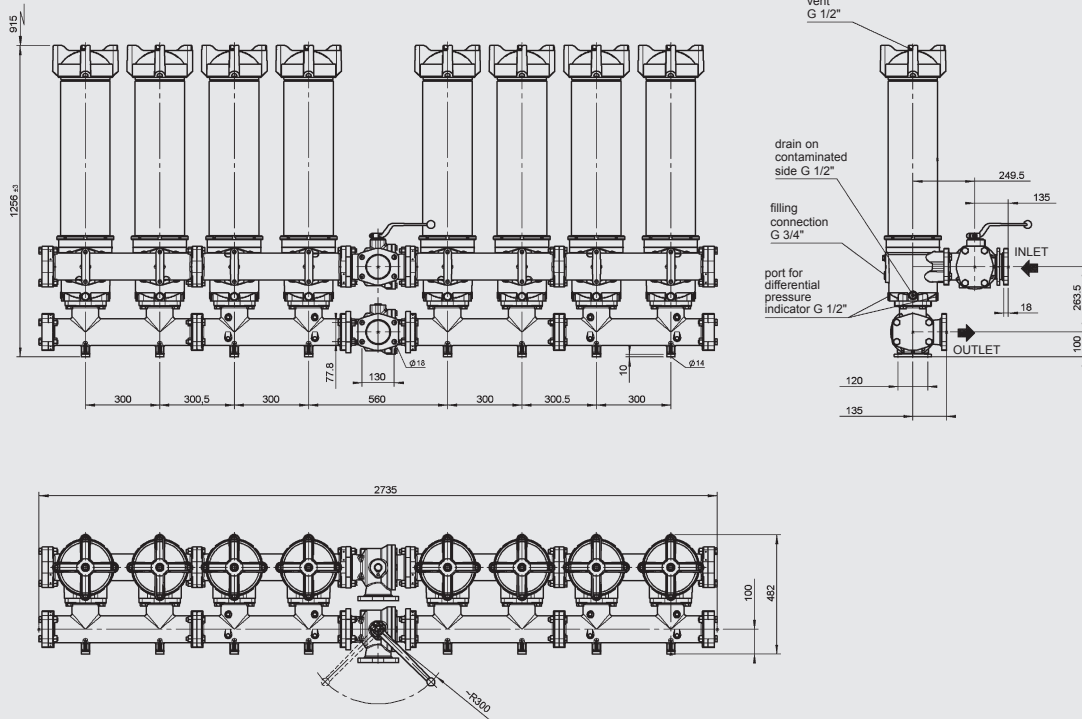

NFD 10440...2.X /-1+4

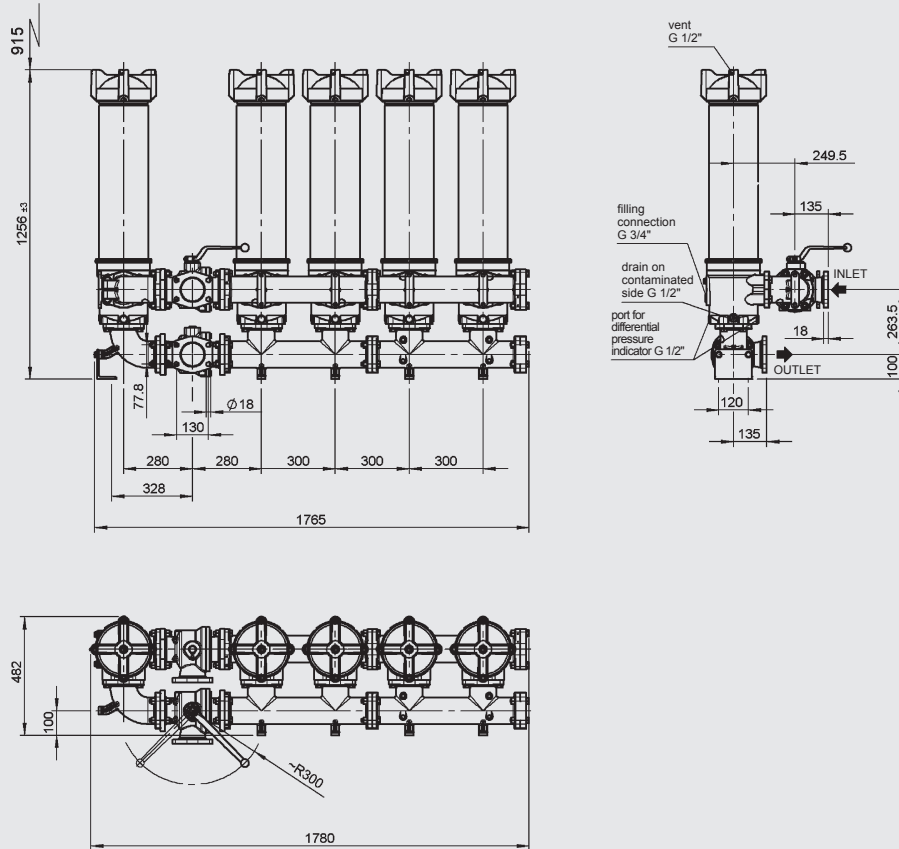

NFD	No. of elements per side	Weight incl. element [kg]	Vol. of pressure chamber [l]
10440	4x 2600 R...	510.4	251.0
10440../-1+4	1x 2600 R... and 4x 2600 R...	328.3	154.0

NOTE

The information in this brochure relates to the operating conditions and applications described. For applications or operating conditions not described, please contact the relevant technical department. Subject to technical modifications.

HYDAC Filbertechnik GmbH
 Industriegebiet
D-66280 Sulzbach/Saar
 Tel.: 0 68 97 / 509-01
 Fax: 0 68 97 / 509-300
 Internet: www.hydac.com
 E-Mail: filter@hydac.com